

## WYPOSAŻENIE STANDARDOWE

- Zaczep trzypunktowy kat. 2
- Płozy boczne regulowane
- Wał samoczyszczący regulowany
- Centralne smarowanie
- Automatyczny napinacz
- Przesów boczny hydrauliczny z zabezpieczeniem mechanicznym
- Amortyzator i akumulator olejopneumatyczny
- Zabezpieczenie mechaniczne

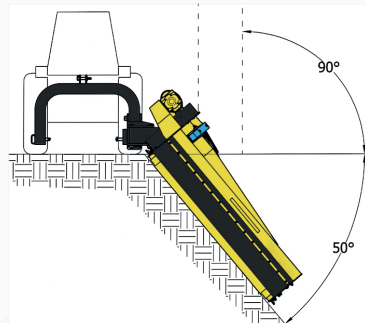

# TORINO

## KOSIARKA BOCZNA PROFESJONALNA

MOD : 160 | 180 | 200 | 220



## NARZĘDZIA

MŁOTEK



NÓŻY



ZACZEP TRZYPUNKTOWY

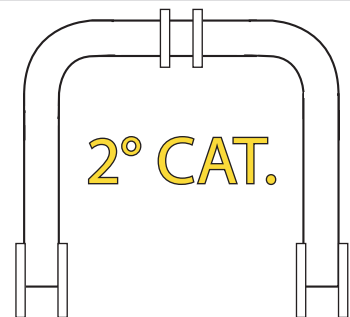

## CHARAKTERYSTYKA

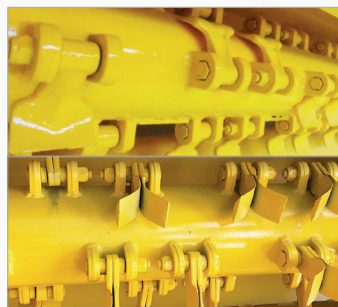

Narzędzia







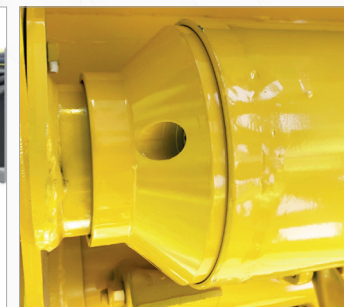

Akumulator olejopneumatyczny



Zabezpieczenie mechaniczne



Mocowanie wału podporowego

SPECYFIKACJA TECHNICZNA					
MODEL	160	180	200	220	
 SZEROKOŚĆ PRACY	160	180	200	220	
 SZEROKOŚĆ MASZyny	185	215	227	245	
 WAGA	730	790	815	840	
 ILOŚĆ MŁOTKÓW / NOŻY	34   68	38   76	44   88	48   96	
 ILOŚĆ PASKÓW	4	4	4	4	
 ZAPOTRZEBOWANIE MOCY	65-110		80-120		

	RIF.	160	180	200	220
PRZESÓW BOCZNY	A	160	180	200	220
	B	195	195	195	195
	C	80	80	80	80
	D	215	235	255	275
	E	223	223	223	223
	F	135	135	135	135

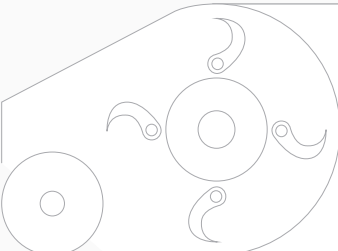
	Ø Rotora	180 mm
	Obroty rotora	1800 obr/min
	Obroty wałka WOM	540
	Ø Wału	177 mm

OPCJE I AKCESORIA
WAŁEK WOM 1700 mm
WAŁEK WOM Z ZABEZPIECZENIEM (WALTERSCHEID)
WERSJA PRZESÓW SX
ŁAŃCUCHY

