

WYPOSAŻENIE STANDARDOWE

- Zaczep trzypunktowy kat 2
- Płozy boczne regulowane
- Wał samoczyszczący regulowany
- Centralne smarowanie
- Automatyyczny napinacz
- Przesów boczny hydrauliczny z zabezpieczeniem mechanicznym
- Amortyzator i akumulator olejopneumatyczny
- Zabezpieczenie mechaniczne

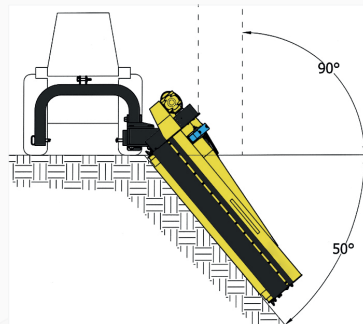

TORINO E

KOSIARKA BOCZNA PROFESJONALNA

MOD : 160 | 180 | 200 | 220 | 240 | 260



NARZĘDZIA

MŁOTEK



NÓŻY



ZACZEP TRZYPUNKTOWY

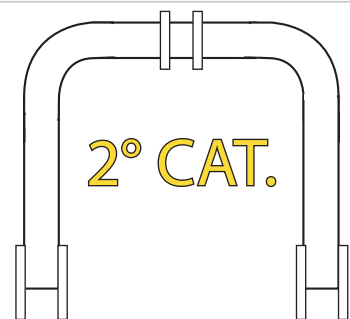

CHARAKTERYSTYKA

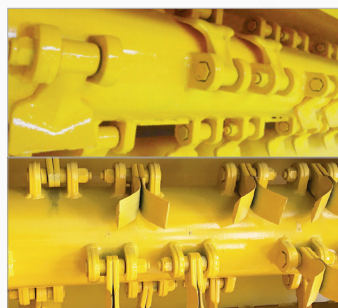

Narzędzia







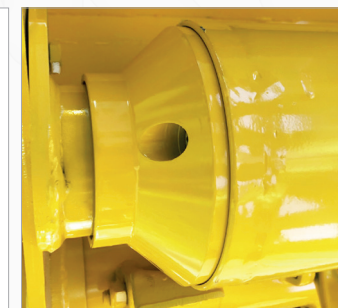

Akumulator olejopneumatyczny



Przekładnia boczna



Mocowanie wału podporowego

SPECYFIKACJA TECHNICZNA							
MODEL	160	180	200	220	240	260	
 SZEROKOŚĆ PRACY	160	180	200	220	240	260	
 SZEROKOŚĆ MASZyny	185	215	227	245	290	310	
 WAGA	870	900	930	960	1020	1050	
 ILOŚĆ MŁOTKÓW / NOŻY	34 68	38 76	44 88	48 96	52 104	56 112	
 ILOŚĆ PASKÓW	4	4	4	4	5	5	
 ZAPOTRZEBOWANIE MOCY	65 -100		80-120		100-160		

	RIF.	160	180	200	220	240	260
PRZESÓW BOCZNY	A	160	180	200	220	240	260
	B	225	225	225	225	225	225
	C	30	30	30	30	30	30
	D	292	312	332	352	372	392
	E	220	220	220	220	220	220
	F	162	162	162	162	162	162

	Ø Rotora	180 mm
	Obroty rotora	1800 obr/min
	Obroty wałka WOM	540
	Ø Wału	177 mm

OPCJE I AKCESORIA
WAŁEK WOM 1700 mm
WAŁEK WOM Z ZABEZPIECZENIEM (WALTERSCHEID)
WAŁEK WOM Z PODÓJNYM ZABEZPIECZENIEM
WERSJA PRZESÓW SX
ŁAŃCUCHY

