

## WYPOSAŻENIE STANDARDOWE

- Zaczep trzypunktowy kat 2
- Stopy podporowe
- Listwa ze światłami
- Obudowa ze stali Hardox



# TAF

## KOSIARKA ŁAŃCUCHOWA

MOD : 150

### NARZĘDZIA

#### ŁAŃCUCHY



## CHARAKTERYSTYKA

ZACZEP TRZYPUNKTOWY

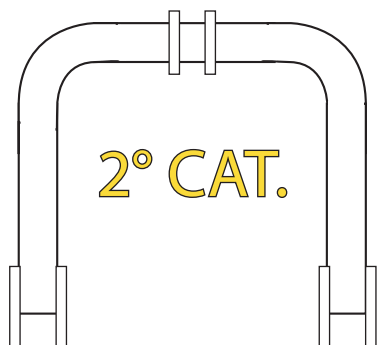

Narzędzia



System sprężyn

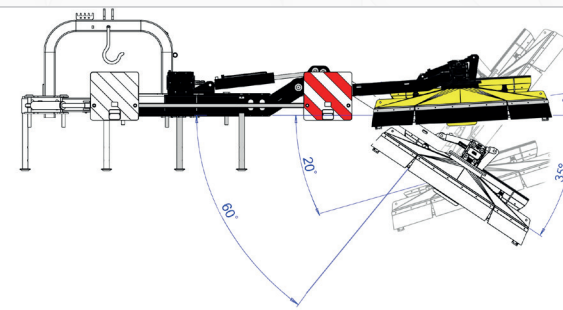

Stopnie nachylenia

## SPECYFIKACJA TECHNICZNA

	MODEL	150
	SZEROKOŚĆ PRACY	150
	SZEROKOŚĆ DROGOWA	2,50
	MAKSYMALNY PRZESÓW	1,00
	MAKSYMALNA WYSOKOŚĆ	3,27
	N ŁAŃCUCHY	2
	WAGA	760
	ZAPOTRZEBOWANIE MOCY	80-130

	RIF.	150
PRZESÓW BOCZNY	A	420
	B	210
	C	75
	D	306
	E	327
	F	123

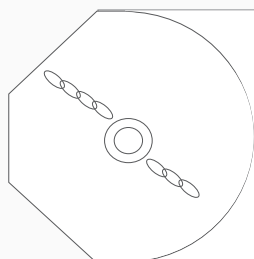

Ø Łańcucha	16X45 mm
Obroty łańcucha	1550 obr/min
OBROTY WAŁKA	540

## OPCJE I AKCESORIA

WAŁEK WOM 1700 mm

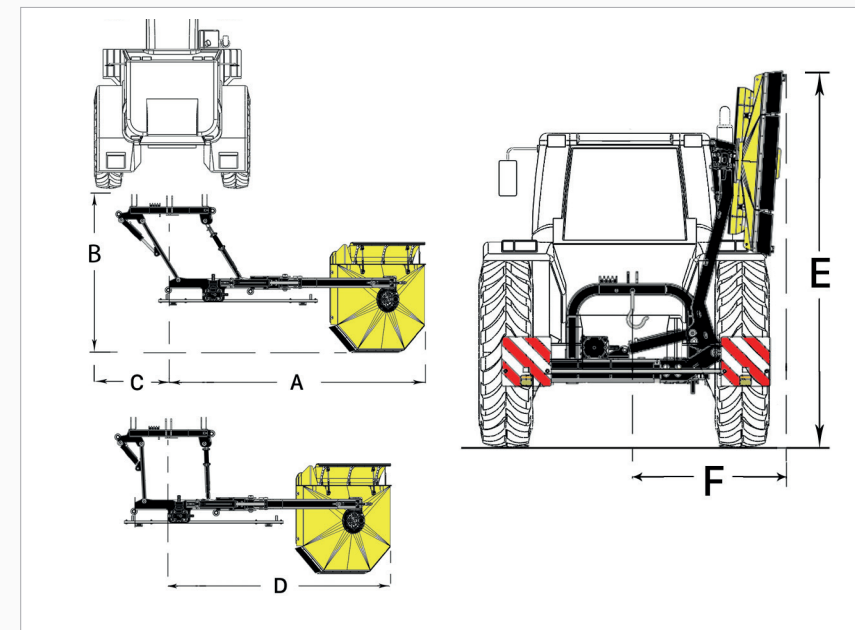

**HARDOX**<sup>®</sup>  
WEAR PLATE