

## WYPOSAŻENIE STANDARDOWE

- Zaczep trzypunktowy kat 2
- Płozy boczne regulowane
- Wał samoczyszczący regulowany
- Centralne smarowanie
- Automatyyczny napinacz
- Przesów boczny hydrauliczny z zabezpieczeniem mechanicznym
- Amortyzator i akumulator hydro-pneumatyczny
- Zabezpieczenie mechaniczne

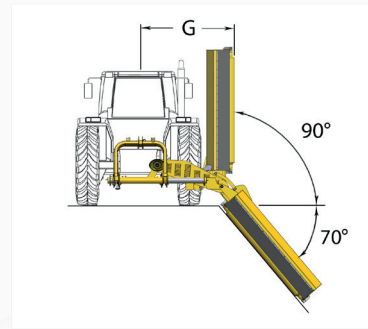

# ROMA

KOSIARKA BOCZNA PROFESJONALNA

MOD : 160 | 180 | 200 | 220 | 240 | 260



## NARZĘDZIA

MŁOTEK



NÓŻ Y



## CHARAKTERYSTYKA

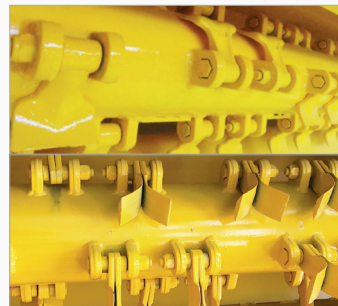

Narzędzia

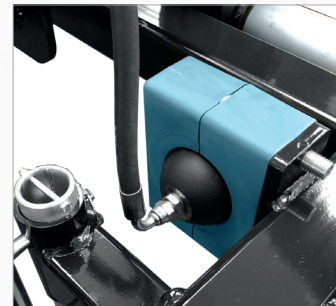

Akumulator olejo-pneumatyczny

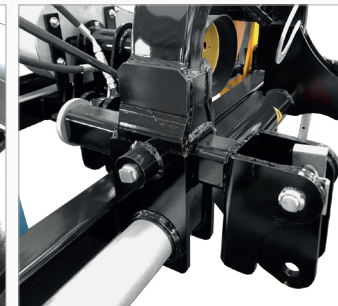

Podwójne zabezpieczenie mechaniczne



Mocowanie wału podporowego

ZACZEP TRZYPUNKTOWY

PRZESUWANY

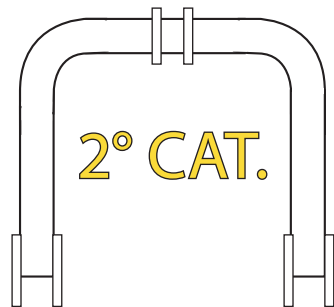

2° CAT.

## SPECYFIKACJA TECHNICZNA

	MODEL	160	180	200	220	240	260
 SZEROKOŚĆ PRACY		160	180	200	220	240	260
 SZEROKOŚĆ MASZyny		207	227	247	267	287	307
 WAGA		1185	1230	1275	1345	1420	1500
 ILOŚĆ MŁOTKÓW / NOŻY		34   68	38   76	44   88	48   96	52   104	56   112
 ILOŚĆ PASKÓW		4	4	4	4	5	5
 ZAPOTRZEBOWANIE MOCY		65 -100		80-120		100-160	

	RIF.	160	180	200	220	240	260
PRZESÓW BOCZNY	A	160	180	200	220	240	260
	B	170	170	170	170	170	170
	C	60	60	60	60	60	60
	D	355	375	395	415	435	455
	E	120	120	120	120	120	120
	F	112	112	112	112	112	112
	H	207	227	247	267	287	307

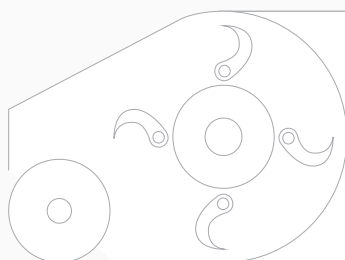

Ø Rotora	180 mm
Obroty rotora	2000 obr/min
Obroty wałka WOM	1000
Ø Wału	177 mm

## OPCJE I AKCESORIA

WAŁEK WOM 1700 mm

