

WYPOSAŻENIE STANDARDOWE

- Zaczep trzypunktowy 1 kat
- Płozy boczne regulowane
- Wał samoczyszczący regulowany
- Napinacz automatyczny
- Amortyzator mechaniczny
- Przeciwnoż przykręcy

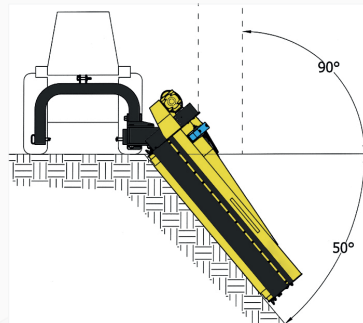

NOVELLO E

KOSIARKA BOCZNA

MOD : 135 | 150 | 165 | 180 | 200



NARZĘDZIA

MŁOTEK

NÓŻ Y 90°



CHARAKTERYSTYKA

ZACZEP TRZYPUNKTOWY

2° CAT.

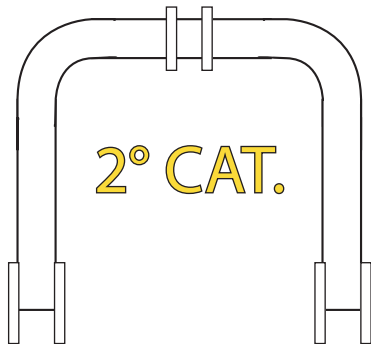

Narzędzia



Przekładnia zewnętrzna









(OPCJA)

Amortyzator mechaniczny



Przeciwnoż przykręcy

SPECYFIKACJA TECHNICZNA						
	MODEL	135 E	150 E	165 E	180 E	200 E
	SZEROKOŚĆ PRACY	135	150	165	180	200
	SZEROKOŚĆ MASZyny	150	165	180	195	215
	WAGA	355	395	435	475	515
	ILOŚĆ MŁOTKÓW / NOŻY	12 24	14 28	14 28	16 32	18 36
	ILOŚĆ PASKÓW	3	3	3	3	3
	ZAPOTRZEBOWANIE MOCY	50-70			70-90	

	RIF.	135 E	150 E	165 E	180 E	200 E
PRZESÓW BOCZY	A	135	150	165	180	200
	B	235	250	265	280	300
	C	40	40	40	40	40
	D	180	180	180	180	180

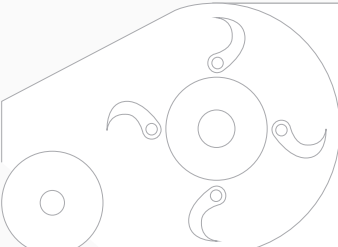
	Ø Rotora	115 mm
	Obroty rotora	2000 obr/min
	Obroty wałka WOM	540
	Ø Wału	139 mm

OPCJE I AKCESORIA
WAŁEK WOM 1700 mm
WAŁEK WOM Z ZABEZPIECZENIEM (WALTERSCHEID)
AKUMULATOR HYDRO-PNEUMATYCZNY

